



Model OTDV-1250

Broadcast Transport Links

OPERATING MANUAL

24926 Highway 108
Sierra Village, CA 95346
Phone: (800) 545-1022
Fax: (209) 586-1022

Table of Contents

Table of Contents	2
SAFETY	3
Safety Precautions	3
Laser Safety Procedure	3
GENERAL FEATURES	4
TRANSMIT SIDE	4
POWER, DATA, ETHERNET, AND OPTICS SIDE	4
Alarm Output Specifications:	5
VIDEO SPECIFICATIONS	5
AUDIO SPECIFICATIONS	5
DATA SPECIFICATIONS	5
ETHERNET SPECIFICATIONS	6
ELECTRICAL, PHYSICAL, ENVIRONMENTAL SPECIFICATIONS	6
NOTES:	6
LED FUNCTIONS:	6
Figure 1 — OTDV-1250-B Block Diagram	7
Figure 2 — OTDV-1250-TA/RA Block Diagram	7
Figure 3 — OTDV-1250-TAA/RAA Block Diagram	8
SFP MODULES	8
Figure 4 — MM 850nm SFP Module with Dual LC Connectors	8
Figure 5 — SM CWDM SFP Module with Dual LC Connectors	8
Figure 6 — SM Bidirectional SFP Module with Single SC Connector	9
INSTALLATION	9
Optical Connectors	9
Cleaning Optical Connectors	9
ORDERING INFORMATION	10

SAFETY

Safety Precautions

The optical emissions from the units are laser-based and may present eye hazards if improperly used. **NEVER USE ANY KIND OF OPTICAL INSTRUMENT TO VIEW THE OPTICAL OUTPUT OF THE UNIT.** Be careful when working with optical fibers. Fibers can cause painful injury if they penetrate the skin.

Laser Safety Procedure

ALWAYS read the product data sheet and the laser safety label before powering the product. Note the operation wavelength, optical output power and safety classifications.

If safety goggles or other eye protection are used, be certain that the protection is effective at the wavelength emitted by the device under test **BEFORE** applying power.

ALWAYS connect a fiber to the output of the device **BEFORE** power is applied. Power should never be applied without an attached fiber. If the device has a connector output, a connector should be attached that is connected to a fiber. This will ensure that all light is confined within the fiber waveguide, virtually eliminating all potential hazard.

NEVER look at the end of the fiber to see if light is coming out. **NEVER!** Most fiber optic laser wavelengths (1310 nm and 1550 nm) are totally invisible to the unaided eye and will cause permanent damage. Shorter wavelengths lasers (e.g., 780 nm) are visible and are very damaging. Always use instruments, such as an optical power meter, to verify light output.

NEVER, NEVER, NEVER look into the end of a fiber on a powered device with **ANY** sort of magnifying device. This includes microscopes, eye loupes and magnifying glasses. This **WILL** cause a permanent and irreversible burn on your retina. Always double check that power is disconnected before using such devices. If possible, completely disconnect the unit from any power source.

If you have questions about laser safety procedures, please call Olson Technology before powering your product.

GENERAL FEATURES

The Olson OTDV-1250 Video/Stereo Audio, Data and Ethernet Fiber Optic Link provides a very high-quality system for transporting baseband video signals, stereo audio signals and bidirectional data with complete EMI immunity via multi-mode or single-mode optical fiber. The combination of RS-250C video, stereo quality audio, data for touch screens, pan, tilt & zoom or pure data transport for communications and the addition of auto-negotiating 10/100Mb/s Ethernet make these links ideal for broadcast, contribution and distribution quality V/A/A transport, teleconferencing, distance learning, and surveillance applications. Each unit is built in a rugged, shielded enclosure. Units are available with four channels of audio and unidirectional transport options.

The defining feature of the OTDV-1250 is versatility. While there are numerous fiber optic broadcast transport links available, the addition of user/field-swappable SFP modules allows the unit to be rapidly reconfigured for any conceivable fiber requirement

All signals are handled using state-of-the-art digital techniques resulting in no degradation in performance regardless of the fiber type and distance. All signals are digitized to a single serial data stream that easily fits into Gb/s data stream. Extensive use of overhead messaging allows the two units to be aware of problems at the far end.

TRANSMIT SIDE

The left side is the transmit side. J1 is the composite video transmit. J2 is the S-video transmit. J3 is the stereo audio transmit. The right side is the receive side. J4 is the composite video receive. J5 is the S-video receive. J6 is the stereo audio receive. D1, D2, D3 & D4 give the status of the unit. Switch S1 selects whether the audio input is configured to be high impedance or 600 Ohms.



POWER, DATA, ETHERNET, AND OPTICS SIDE

The left side is the power and alarm section. Pins 1 & 2 of J7 are the DC power input. Pins 3 and 4 are the alarm output. The center section is the data interface. J8 is the low-speed data interface. Switch S2 is used to select RS-232 or RS-422. J9 is the bidirectional 10/100Mb/s Ethernet data port. The right side contains the SFP module interface (J10) and the unit status LED (D5).



Alarm Output Specifications:

The alarm output is driven by a normally closed MOSFET. It should be pulled to an external voltage (50V max) through a resistor. The MOSFET has a typical “on” resistance of 330 ohms. The external resistor should be chosen such that the maximum current is less than 25mA.

The alarm output is at high impedance when the unit is functioning properly, and at low impedance when there is no power or no optical signal is present at the receiver, or the SFP is missing.

VIDEO SPECIFICATIONS

	Min.	Typ.	Max.	Units
Input Signal	Composite or S-Video			(See Note 1)
Output Signals	Composite and S-Video			
I/O Impedance		75		Ohms
Input Level	0.6	1.0	1.4	V _{p-p}
Output Level		1.0		V _{p-p} (See Note 2)
Bandwidth		6		MHz
SNR (NTC7 Lum-Weighted)	67	72.5		dB
SNR (Unified Lum-Weighted)	67	73.0		dB
Differential Gain		1.3		%
Differential Phase		0.7		°
Line Time Distortion	0	0.25	0.50	%
Chrom-Lum Delay	-20	0	+20	ns
Chrom-Lum Gain	98	100	103	%
Conversion	10-bit 4:2:2 per ITU-R-BT.601			

AUDIO SPECIFICATIONS

	Min.	Typ.	Max.	Units
Number of Channels	2		4	(See Note 3)
Frequency Response	20		20,000	Hz
THD+N	-85		-78	dB
Input Impedance	600		10,000	Ohms (See Note 4)
Input Level (600 Ohm Bal.)	16	16.5	17	dBu
Gain	-1		0	dB
Input Level (High Impedance, Single Ended)			0.9	V _{p-p}

DATA SPECIFICATIONS

	Min.	Typ.	Max.	Units
Number of Channels		1		
Protocol	RS-232 or RS-422			(See Note 5)
Data Rate (RS-232)			155	kb/s
Data Rate (RS-422)			1	Mb/s

ETHERNET SPECIFICATIONS

	Min.	Typ.	Max.	Units
Number of Channels			1	
Auto Negotiating	10Mb/s or 100Mb/s			

ELECTRICAL, PHYSICAL, ENVIRONMENTAL SPECIFICATIONS

	Min.	Typ.	Max.	Units
DC Input Voltage	10		20	V _{DC} (See Note 6)
DC Current	0.30		0.53	A (See Note 6)
Power		6		W (See Note 6)
Module Weight		25.4		oz.
Module Dimensions	11.5 x 6 (with base plate) x 1.25			inch
Operating Temp. Range	0		+50	°C
Storage Temp. Range	-10		+60	°C
Humidity	5		90	%

NOTES:

- 1) The transmitter accepts either composite or S-Video input. If both are present, the S-Video signal will be used. The receiver always presents both composite and S-Video outputs.
- 2) The output level will track the input level.
- 3) The standard transceiver model offers either two or four audio channels.
- 4) Input impedance is switch selectable by the user. The high impedance setting is single end input.
- 5) The data protocol is switch selectable by the user.
- 6) The OTDV-1250 utilizes high-efficiency switching power supplies internally. The power dissipation is nearly constant as the input voltage changes. The highest current draw will occur at the lowest input voltage and vice versa. Note that excessive noise and ripple on the power supply may degrade some of the performance parameters.
- 7) All test results are at +25°C with a +15Volt DC power supply.

LED FUNCTIONS:

LED ID	Description	Green	Red	Orange	Off
D1	Composite video input present	Solid green when composite video present and no S-video present. Slow flashing green when composite video present and S-video present	N/A	N/A	No Composite video present
D2	S-video input present	S-video present	N/A	N/A	No S-video present
D3	Unit status	Unit functioning properly	No optical signal In or missing SFP	No optical signal into far end unit	No power
D4	Received video present	Transmitter has valid video	N/A	N/A	No video at transmitter

LED ID	Description	Green	Red	Orange	Off
D5	Unit status	Unit functioning properly	No optical signal In or missing SFP	No optical signal into far end unit	No power
Left Ethernet LED	Connection Speed	10 Mb/s	N/A	100 Mb/s	No Connection
Right Ethernet LED	RX Data	N/A	N/A	Receiving data from RJ-45 jack	Not receiving data

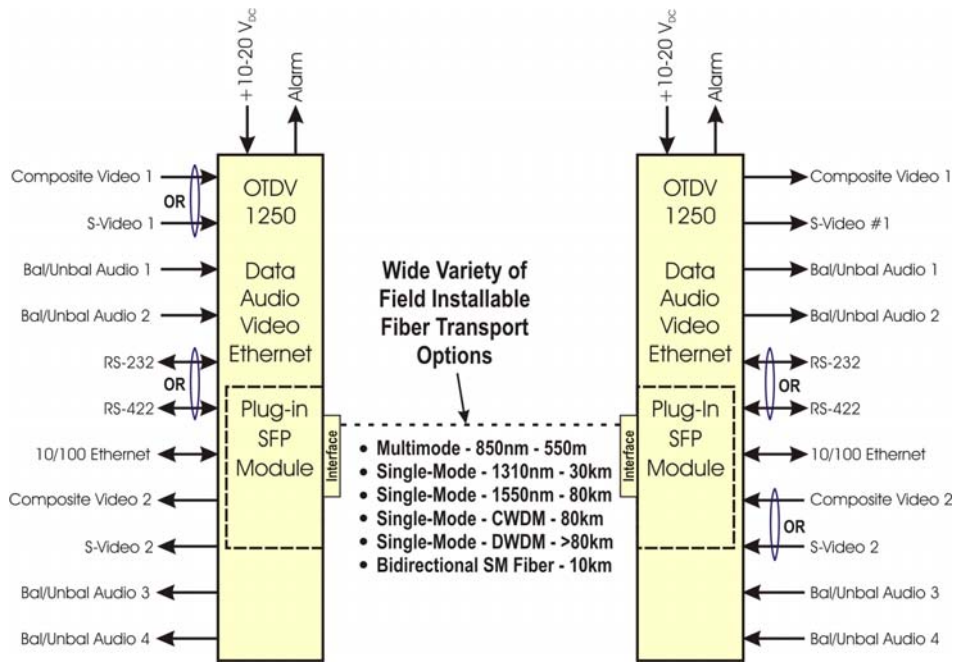

Figure 1 — OTDV-1250-B Block Diagram

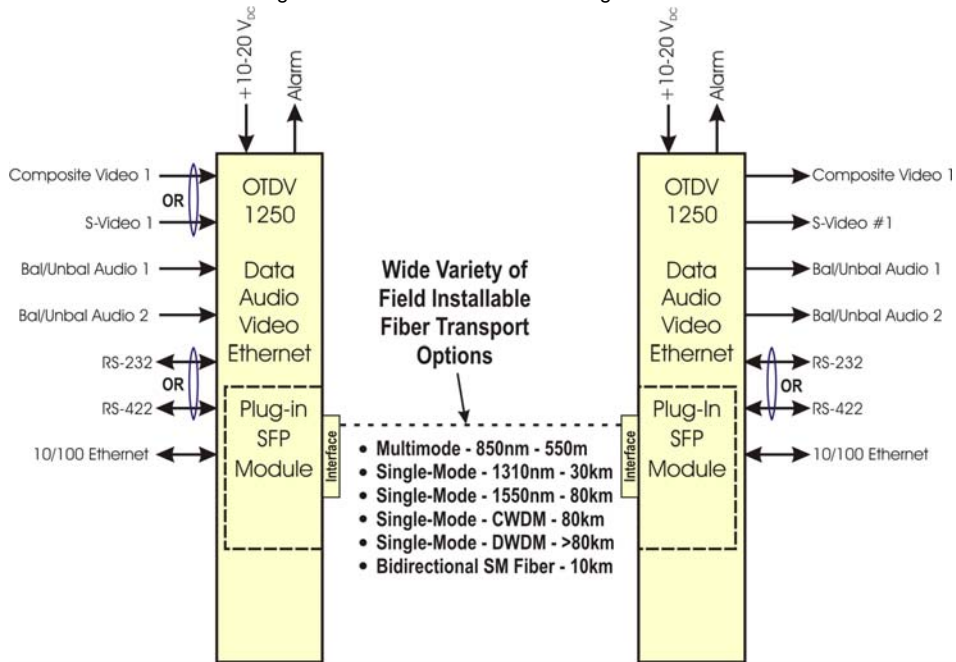

Figure 2 — OTDV-1250-TA/RA Block Diagram

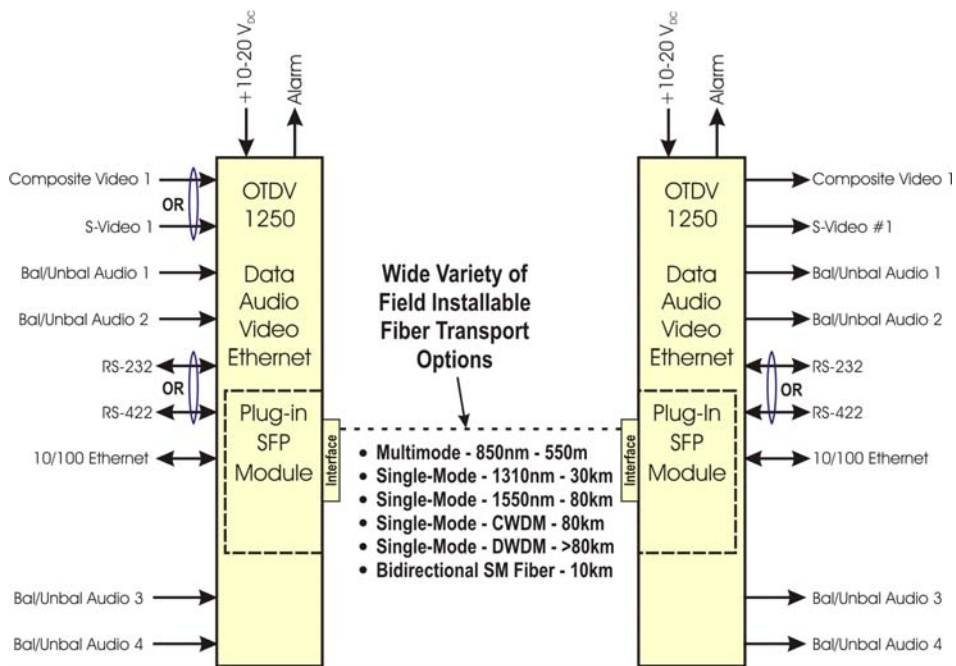

Figure 3 — OTDV-1250-TAA/RAA Block Diagram

SFP MODULES



Figure 4 — MM 850nm SFP Module with Dual LC Connectors

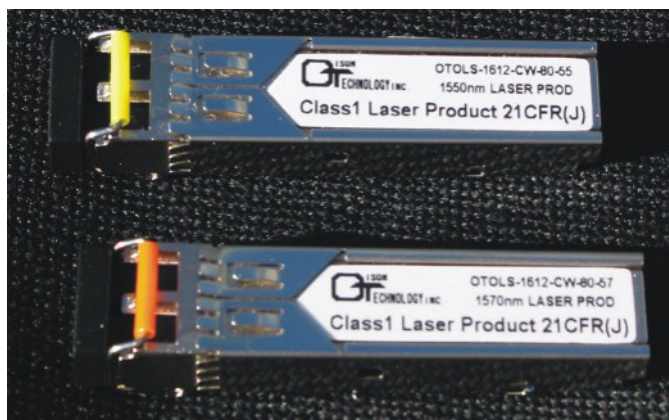

Figure 5 — SM CWDM SFP Module with Dual LC Connectors

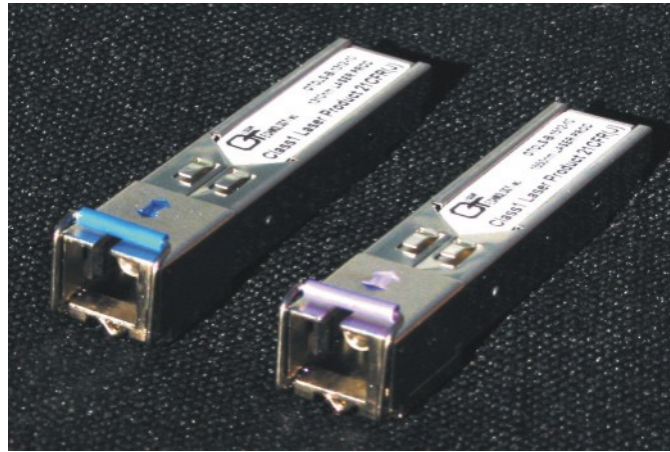

Figure 6 — SM Bidirectional SFP Module with Single SC Connector

INSTALLATION

Optical Connectors

There are many optical connectors on the market. The OTDV-1250 offers LC and SC/UPC types of connectors. One of the most common errors encountered in the field is the use of the wrong type of connectors. The most common is using SC/PC (Flat) with SC/APC(angled). The connectors will fit together but the optical loss will be high and performance is unpredictable and both connectors may be permanently damaged.

Cleaning Optical Connectors

Fiber optic connectors should be clean and capped, so one can usually remove the cap and make the connection without cleaning the connector but if there is any doubt, clean the optical connectors before making the connection. After making the connection, there is no need clean the connector while the connector remains connected. Use caution when handling the connectors. Any grease from your finger, scratches or small pieces of dust can strongly affect performance. To clean, use a lint-free wipe such as Kimwipes or cotton swab, moisten with alcohol and gently wipe the tip of the connector. Let the connector air dry completely or use dry compressed air to dry. When making the connection, be sure the key aligns with the bulkhead connector. With LC connectors, gently press in until the connector “clicks” in to place.

ORDERING INFORMATION

OTDV-1250 Platform

	Description
OTDV-1250-B	Bidirectional Digital Video, Audio, Data Transport Link (Order SFP Separately.)
OTDV-1250-TA	Transmit Only, Digital Video, Audio, Data Transport Link (Order SFP Separately.)
OTDV-1250-RA	Receive Only, Digital Video, Audio, Data Transport Link (Order SFP Separately.)
OTDV-1250-TAA	Transmit Only, Digital Video, Quad Audio, Data Transport Link (Order SFP Separately.)
OTDV-1250-RAA	Receive Only, Digital Video, Quad Audio, Data Transport Link (Order SFP Separately.)

SFP Modules

	Description
OTOLS-8512-02	SFP Optic Module, Dual MM Fiber , 850nm, 550 meter max, LC Connector
OTOLS-1312-30	SFP Optic Module, Dual SM Fiber 1310nm, 30km max, LC Connector
OTOLS-1512-80	SFP Optic Module, Dual SM Fiber 1550nm, 80km max, LC Connector
OTOLS-1612-CW-80-27	SFP Optic Module, Dual SM Fiber, CWDM, 1270nm, 80km max, LC Connector
OTOLS-1612-CW-80-29	SFP Optic Module, Dual SM Fiber, CWDM, 1290nm, 80km max, LC Connector
OTOLS-1612-CW-80-31	SFP Optic Module, Dual SM Fiber, CWDM, 1310nm, 80km max, LC Connector
OTOLS-1612-CW-80-33	SFP Optic Module, Dual SM Fiber, CWDM, 1330nm, 80km max, LC Connector
OTOLS-1612-CW-80-35	SFP Optic Module, Dual SM Fiber, CWDM, 1350nm, 80km max, LC Connector
OTOLS-1612-CW-80-37	SFP Optic Module, Dual SM Fiber, CWDM, 1370nm, 80km max, LC Connector
OTOLS-1612-CW-80-39	SFP Optic Module, Dual SM Fiber, CWDM, 1390nm, 80km max, LC Connector
OTOLS-1612-CW-80-41	SFP Optic Module, Dual SM Fiber, CWDM, 1410nm, 80km max, LC Connector
OTOLS-1612-CW-80-43	SFP Optic Module, Dual SM Fiber, CWDM, 1430nm, 80km max, LC Connector
OTOLS-1612-CW-80-45	SFP Optic Module, Dual SM Fiber, CWDM, 1450nm, 80km max, LC Connector
OTOLS-1612-CW-80-47	SFP Optic Module, Dual SM Fiber, CWDM, 1470nm, 80km max, LC Connector
OTOLS-1612-CW-80-49	SFP Optic Module, Dual SM Fiber, CWDM, 1490nm, 80km max, LC Connector
OTOLS-1612-CW-80-51	SFP Optic Module, Dual SM Fiber, CWDM, 1510nm, 80km max, LC Connector
OTOLS-1612-CW-80-53	SFP Optic Module, Dual SM Fiber, CWDM, 1530nm, 80km max, LC Connector
OTOLS-1612-CW-80-55	SFP Optic Module, Dual SM Fiber, CWDM, 1550nm, 80km max, LC Connector
OTOLS-1612-CW-80-57	SFP Optic Module for Dual SM Fiber, CWDM, 1570nm, 80km max, LC Connector
OTOLS-1612-CW-80-59	SFP Optic Module for Dual SM Fiber, CWDM, 1590nm, 80km max, LC Connector
OTOLS-1612-CW-80-61	SFP Optic Module for Dual SM Fiber, CWDM, 1610nm, 80km max, LC Connector
OTOLS-BI1312-10	SFP BiDi Optic Module for One SM Fiber, 1310nm Tx, 10km max, SC Connector
OTOLS-BI1512-10	SFP BiDi Optic Module for One SM Fiber, 1550nm Tx, 10km max, SC Connector

Power Supply Part Numbers

OTPS-12A-4P	Power Supply, 100-240 Volts AC, 50-60 Hz
-------------	--